



Atlantis®

Design guide - Atlantis® patient-specific abutments and crowns



Atlantis®

CONTENTS

This manual provides an instructional overview of laboratory procedures and design options for Atlantis patient-specific abutments and crowns.

Atlantis abutments can be designed and produced for all major implant systems* and are available in titanium, gold-shaded titanium and zirconia.

Introduction	4
Atlantis patient-specific abutments	4
Virtual Atlantis Design (VAD)	4
Laboratory procedure	5
Anatomy	6
Emergence shape options	6
Emergence width options	7
Abutment outcomes	10
Implant placement	10
Additional options	11
Abutment design parameters	12
Atlantis temporary restorations	13
Atlantis Tissue Sculpting Concept	13
Atlantis Healing Abutment	14
Atlantis Temporary Crown	15
Atlantis Abutment	16
Atlantis Crown, Cut-back	17
Atlantis Crown, Full-contour	18
Atlantis Crown File	19
Atlantis Core File	20
Atlantis Insertion Guide	20
Atlantis Crown Abutment	21
Atlantis CustomBase solution	23
Atlantis CustomBase solution - Atlantis Crown	24
Atlantis CustomBase solution - Atlantis Crown File	25
Atlantis CustomBase solution - Atlantis Core File	25
Atlantis Conus Abutment - overdenture	26
Atlantis Conus Abutment - custom	28
Duplicate abutment	29
Later order	30
Atlantis Printed Model	31
Diagnostic wax-up	31
Stone models	32
Articulator guide	32
Design terminology	33
Questions & Answers	34

*Refer to the latest version of Atlantis implant compatibility chart and Atlantis WebOrder.

To improve readability for our customers, Dentsply Sirona does not use ® or ™ in body copy. However, Dentsply Sirona does not waive any right to the trademark and nothing herein shall be interpreted to the contrary.

Introduction

Atlantis® patient-specific abutments

Atlantis abutments are available for cement-, screw- and attachment-retained, implant-supported restorations for all major implant systems*. All abutments are delivered with the corresponding abutment screw.



Atlantis® temporary restorations

For single-tooth cement- or screw-retained restorations. Available as custom healing abutments or as temporary crowns.

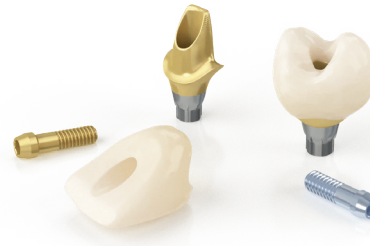

Atlantis® CustomBase solution

For screw-retained restorations, available in titanium and gold-shaded titanium.



Atlantis® Abutment and crowns

For cement-retained crown or bridge restorations available in titanium, gold-shaded titanium and four shades of zirconia.**



Atlantis® Conus Abutment - overdenture

For attachment-retained restorations utilizing a friction fit. Designed to fit SynCone 5° caps. Available in titanium.



Atlantis® Crown Abutment

For single-tooth, screw-retained crowns, available in titanium and five shades of zirconia, including a translucent zirconia in white.**



Atlantis® Conus Abutment - custom

For attachment-retained restorations utilizing a friction fit, with more individual design options. Available in titanium and gold-shaded titanium.

*Refer to the latest version of Atlantis implant compatibility chart and Atlantis WebOrder.

**Images shown for communication purposes only and should not be used as a representation of the exact material color.

Laboratory procedure

An Atlantis WebOrder user guide is available for support in placing your abutment orders. Contact your Dentsply Sirona representative for assistance with your first order and to receive start-up materials:

- Training on how to use the Atlantis WebOrder
- Atlantis WebOrder user guide
- Atlantis CaseSafe boxes for shipping your cases
- Information regarding lab-based and intraoral scanning for Atlantis abutments

Below is the laboratory step-by-step procedure for ordering of an Atlantis abutment.

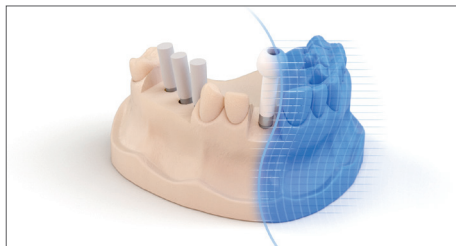

1. Scanning

Implant level impression (digital or conventional) is taken by the clinician. The scanning (either with an intraoral or a model scanner) is performed with an approved scanner and scanbody for Atlantis solutions, please refer to the user guide for the scanner in use. The user guides can be found at the help pages at Atlantis WebOrder. When working with conventional impressions, the model should have a removable, stable silicone soft tissue mask. (For more information, see page 20.)

If no scanning is made, the model can be shipped using the Atlantis CaseSafe which ensures safe transport of the case materials. All cases need to be articulated using a small articulator/occludator, a diagnostic wax-up can replace the opposing model but a model is preferred.

If using an articulator with a removable base plate, it is only necessary to ship the model mounted on the plate and not the entire articulator.

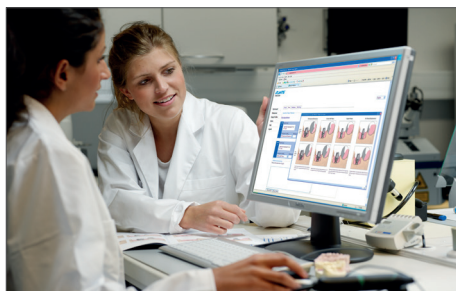

2. Atlantis® WebOrder

Enter your order in Atlantis WebOrder* (www.atlantisweborder.com), and personalize the design to the patient's specific needs by modifying the abutment design preferences. If physical models are shipped, print and send the order ticket with the models in an Atlantis CaseSafe to the Atlantis manufacturing facility.

Note: Please refer to "Atlantis shipping guide" for detailed shipping instructions.

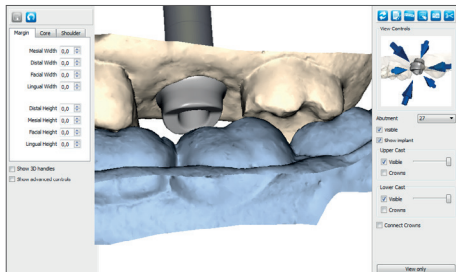

3. Design

Once your models are received, they are scanned and generated into a virtual 3D image that is then used for the individual design of the Atlantis abutment in Virtual Atlantis Design (VAD) software.



4. Manufacturing

Upon your approval of the virtual abutment design (if requested), your Atlantis abutment is manufactured and measured to check that the milling was done according to the specifications and within the tolerances.

Finally the milled abutment is verified towards the order you entered in Atlantis WebOrder and the Virtual Atlantis Design (VAD) software.

5. Final restoration

When the abutment is received at the lab, the final restoration can be fabricated.

Note: The Atlantis abutment screw delivered with the abutment should always be used by the clinician for final seating of the abutment in the mouth. In Atlantis WebOrder, extra screw(s) can be ordered together with each case to be used in the laboratory during fabrication of the final restoration.



*New users must register to access Atlantis WebOrder. Click the Register link to start the process.

Anatomy

Teeth are not round. In order to create implant restorations that look and function like natural teeth, anatomically shaped abutments allow you to provide results of the highest esthetics and function.

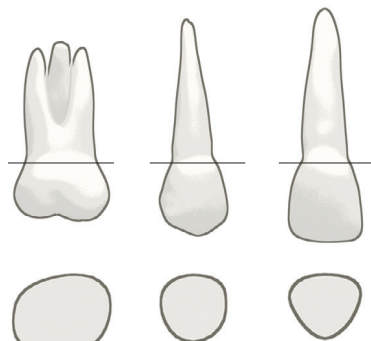

Reference:
Wheeler's Dental Anatomy, Physiology and Occlusion, Major M. Ash, Stanley Nelson

Virtual Atlantis® Design (VAD) images

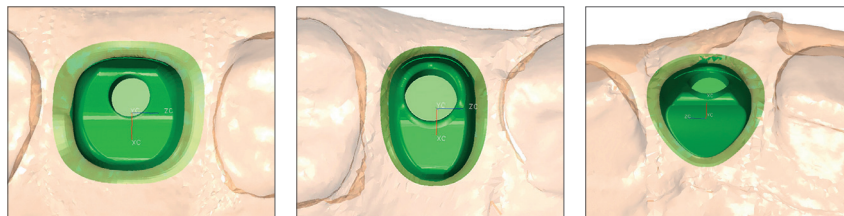

Atlantis abutments are designed to correspond with the shape of natural teeth. Customer preferences together with the Virtual Atlantis Design (VAD) software are used to create individual abutments for each patient and situation.

Emergence shape options

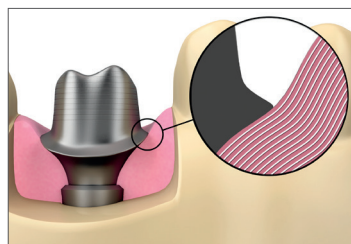

Concave

The shape between the interface and the margins (preparation line) will be concave, in order to reduce tissue pressure.

Note: If no selection is indicated in your order, the Atlantis abutment will be fabricated with this shape by default.

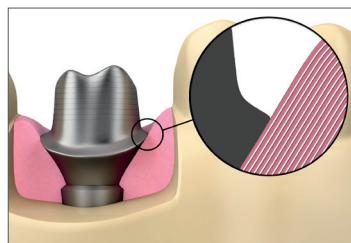

Straight

The shape between the interface and the margins (preparation line) will be straight.

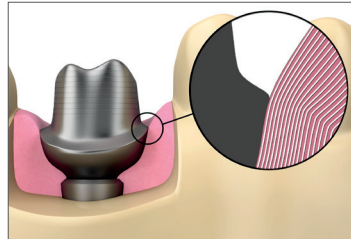

Convex

The shape between the interface and the margins (preparation line) will be convex.

Emergence width options

The design of Atlantis abutments is based on several factors, including the size of the healing space, the emergence width option chosen during order placement and the position of the restorative margin.

The healing situation can vary depending on the size of the healing abutment used. It is therefore important to choose the appropriate emergence width option that will create the abutment size needed to effectively support the final restoration.

For example, the combination of narrow healing situations and larger crown restorations could require the selection of the “Full anatomical dimensions” emergence width option, but may cause high compression on the soft tissue. A surgical incision may be required to seat the abutment.

1. No tissue displacement

Abutment with no soft tissue support. The abutment does not touch the soft tissue.

Note: If a stone model of the soft tissue is provided, the abutment can only be designed with this emergence width option.

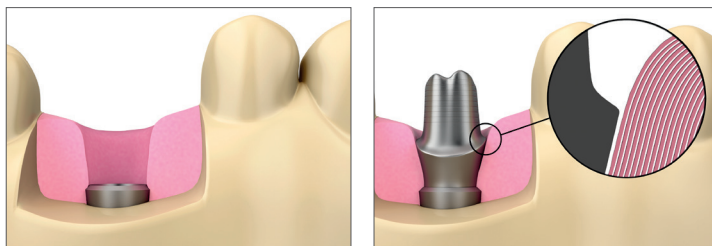

Narrow healing space

The design of the abutment may be smaller than desired due to the required smoothing of the emergence shape. The abutment will not touch the soft tissue.

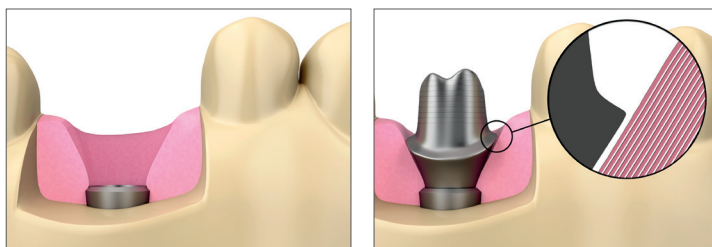

Wide healing space

In a larger sized healing situation, the abutment will be larger, but the abutment will not touch the soft tissue.

2. Support tissue

Anatomically-shaped abutment up to 0.2 mm larger than the sulcus of the silicone soft tissue model provided.

The size of the abutment will be determined by the space created by the healing/temporary abutment for an “easy” insertion.

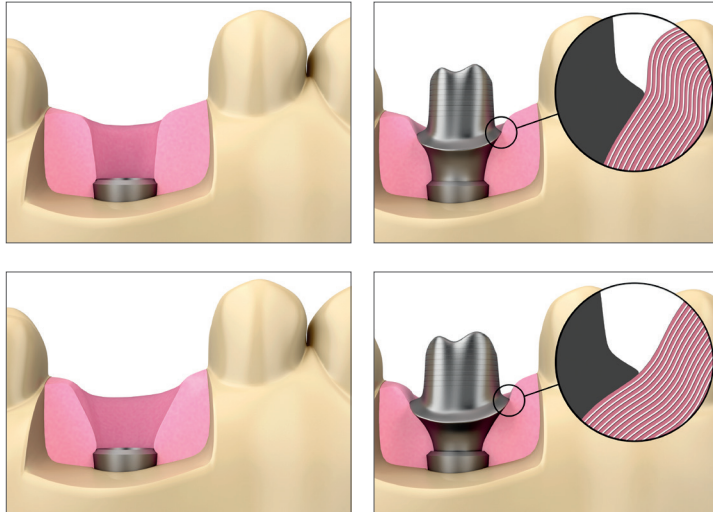

Narrow healing space

The design of the abutment will apply light pressure on the soft tissue. A narrow healing space will result in a smaller sized abutment.

Wide healing space

The design of the abutment will apply light pressure on the soft tissue. A larger healing space, will result in a larger sized abutment.

3. Contour tissue

Medium diameter, anatomically-shaped abutment up to 1.0 mm larger than sulcus of model of soft tissue provided.

The design of the abutment may cause temporary blanching of the soft tissue.

The size of the abutment is determined by the space created by the healing/temporary abutment.

Note: If no selection is indicated in your order, the Atlantis Abutment will be fabricated with this emergence width option by default.

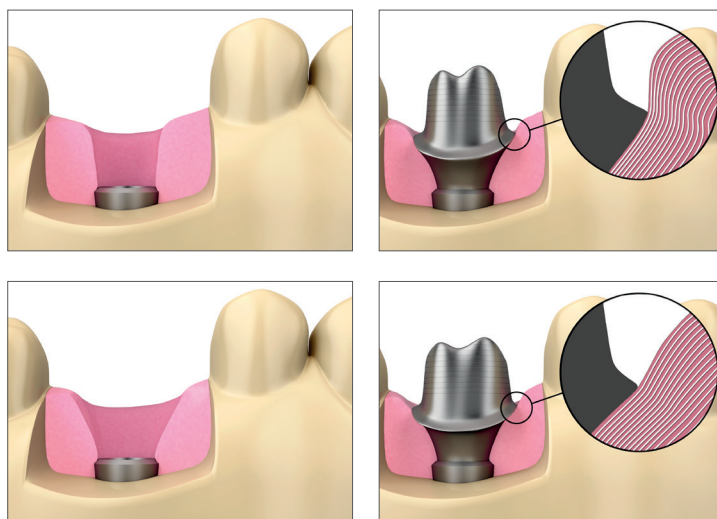

Narrow healing space

The abutment design will have a maximum of 1.0 mm of soft tissue compression. A narrow healing space will result in a smaller sized abutment.

Wide healing space

The abutment design will have a maximum of 1.0 mm of soft tissue compression. A larger healing space will result in a larger sized abutment.

4. Full anatomical

Largest diameter abutment provided with best emergence profile possible.

The design of the abutment is based on the best emergence profile possible, not taking the soft tissue situation into consideration.

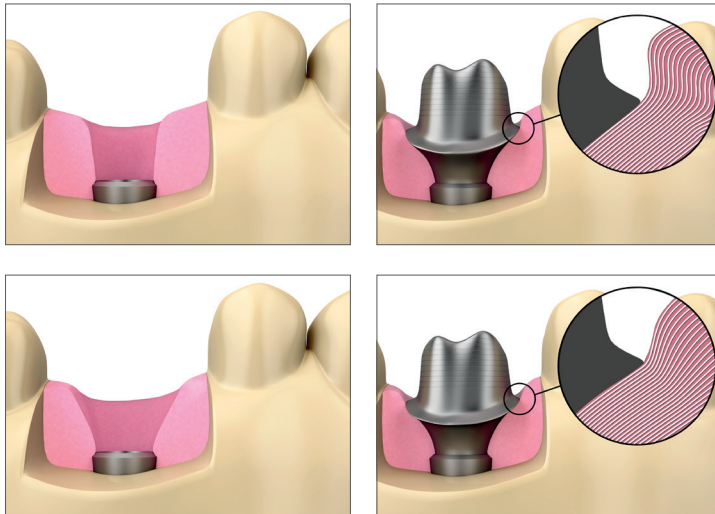

Narrow healing space

Can create a high compression when there is a narrow healing space. A surgical incision for placement may be required.

Wide healing space

In situations with a wider healing space, the compression on the soft tissue will be less

5. Anatomical support

Abutment with the least soft tissue compression, using maximum concave emergence shape, and designed based on following criteria:

- The size of the abutment is determined by the best emergence profile possible.
- The margins (preparation line) will be placed at gingiva level or just below gingiva level.
- The emergence shape will be as concave as possible.

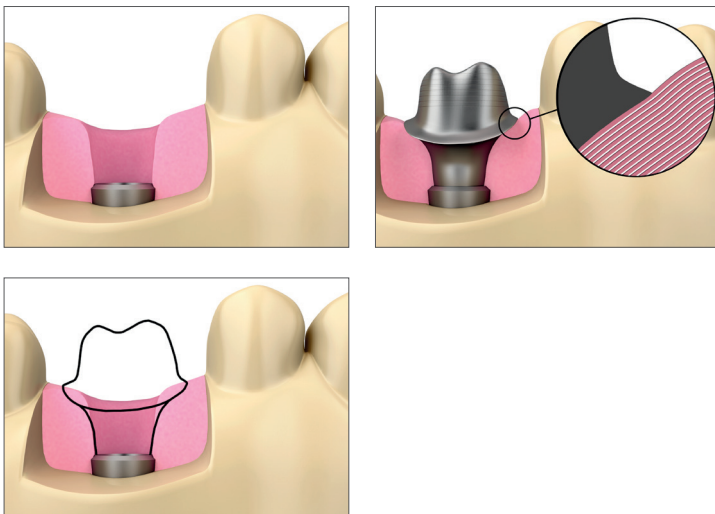

Narrow healing space

Ideal situation for the use of Anatomical support; narrow healing space compared to the edentulous situation in the “non-esthetic” zone.

Note: Not applicable on wide healing situations.

Abutment outcome

Abutment outcomes

Depending on the soft tissue situation, your selection of emergence width option may result in significant differences in the abutment size.

A - Full anatomical **B** - Contour tissue* **C** - Support tissue **D** - No tissue displacement

*Default if no selection is made

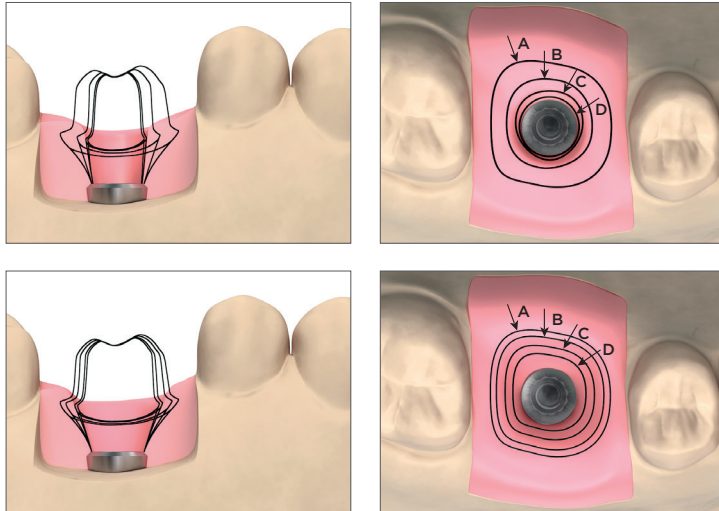

Narrow healing space

There may be more significant differences in the abutment design between each of the emergence width options.

Wide healing space

There will be smaller differences in the abutment design for each of the emergence width options.

Implant placement

When the implant is placed in a non-ideal position, the choice of margin position and emergence width option has a great influence on the outcome of the abutment. The most common situations are described and illustrated below.

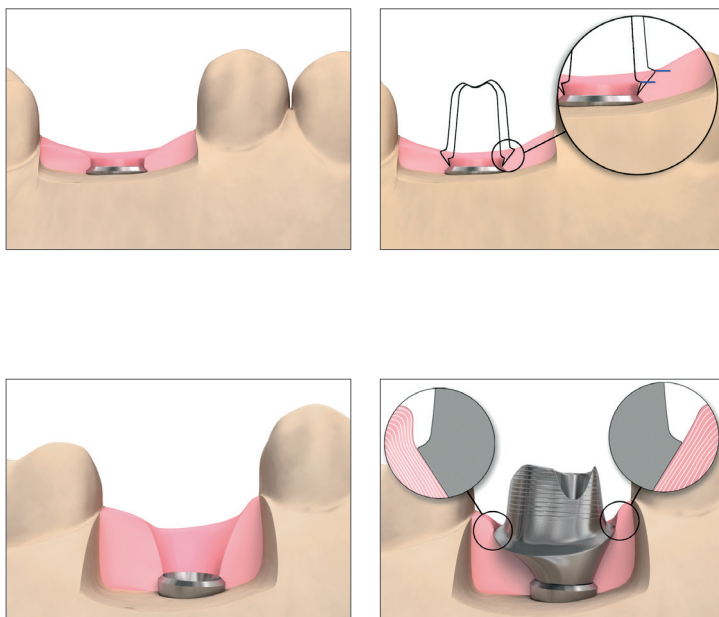

Shallow implant placement

When minimal soft tissue depth is available and a subgingival margin position is selected, the total abutment width will be limited.

Note: A supragingival margin together with emergence width option “full anatomical dimensions” or “contour soft tissue” will create a wider abutment, but may result in exposed abutment margins. Emergence width option “anatomical support” is not applicable for shallowly placed implants.

Off-center implant placement

When the implant position is off-center compared to the required final tooth restoration, the Atlantis abutment can be designed to compensate for the off-center placement through the selection of either emergence width option full anatomical dimensions or contour soft tissue, which will allow for a higher compression of the soft tissue.

Additional options

Margin position options

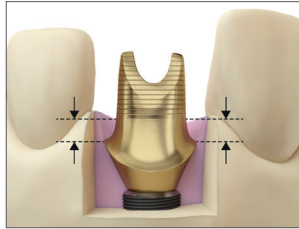

Use subgingival depth
Margin depths measured from gingival crest to abutment margin.

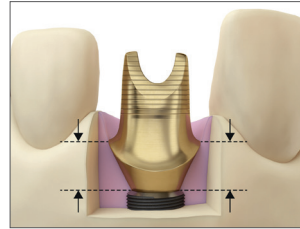

Use heights above interface
Margin depths measured from implant surface to abutment margin.

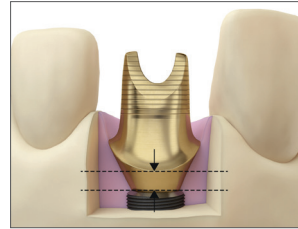

As close to interface as possible.

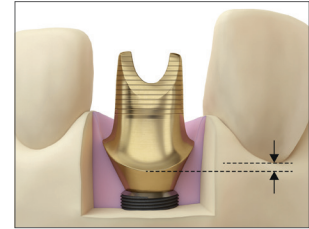

Use neighbouring teeth.

Margin design

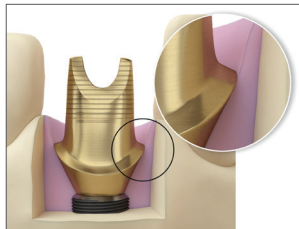

Shoulder

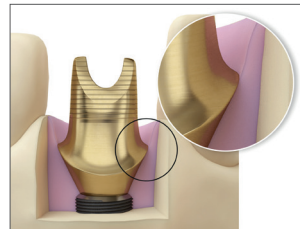

Chamfer

Margin bevel

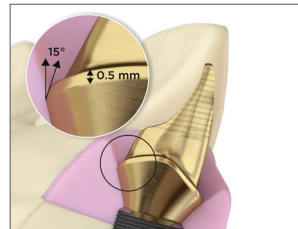

Gingival bevel
(not available in zirconia)

Retentive surface

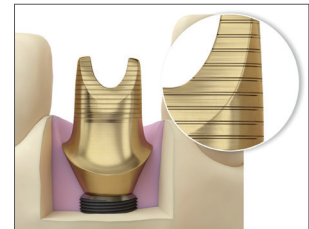

Retentive surface titanium
(not available in zirconia)

Parallel abutments

If the final restorations for a case will be splinted, the abutments must be designed to be parallel. When ordering multiple Atlantis abutments for an individual case, be sure to indicate which abutments should be parallel to each other. Requests of having abutments designed parallel to prepared teeth can be made but parallelism cannot be guaranteed.

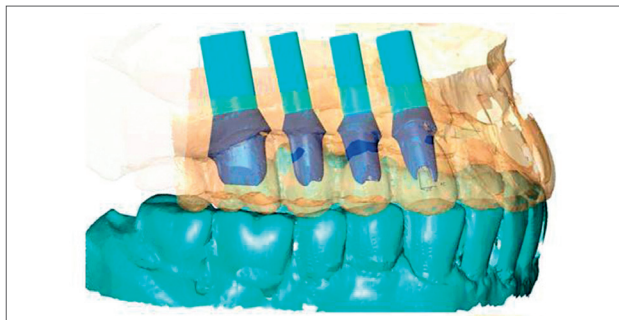

Abutment design parameters

Abutment material: Titanium

The abutment diameter ranges from 3.3 to 12 mm, the maximum abutment height is 15 mm above the implant interface and the minimum height is 4 mm above the transmucosal collar. The abutment is provided straight and up to 30° of angulation.

Abutment material: Zirconia

The abutment diameter ranges from 3.45 mm to 9.50 mm, the maximum abutment height is 13.8 mm above the implant interface and the minimum height is 4 mm above the transmucosal collar. The abutment is provided straight and up to 30° of angulation.

Note: The values mentioned above (for both abutment materials) are case dependent, meaning that they vary from case to case. For example, a titanium abutment that is angled 30° from the implant direction is not possible to design 15 mm high.

Atlantis® Tissue Sculpting Concept

Atlantis Tissue Sculpting Concept enables you to take control of your patient's soft tissue healing, based on the emergence profile of the final restoration. Used in a one-stage and two-stage surgery procedure, the concept works for both cement- and screw-retained restorations for your choice of implant system.

The design of the patient-specific temporization

The design of the tissue sculpting product can be re-used for your patient's final restoration, avoiding the need for a second impression. Instead, save chair time and improve patient comfort, while ensuring a superb and predictable esthetic outcome.



Implant surgery and healing



Final restoration workflow

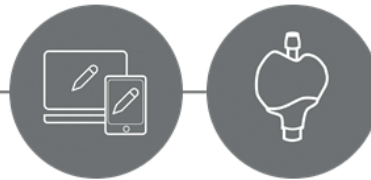

Atlantis® Healing Abutment

The patient-specific Atlantis Healing Abutment can be used with an endosseous implant for temporary use during soft tissue healing after one-stage and two-stage surgeries.

The Atlantis Healing Abutment is designed based on the planned final Atlantis Abutment and crown, using the same emergence profile to more easily achieve an esthetic outcome during the soft tissue healing phase.

The ideal emergence profile is transferred to the final Atlantis Abutment, which minimizes interference of the mucosa at the time of placing the final restoration. This enhances patient comfort and speeds up the procedure.

There is a dimple marked on the lingual side of the Atlantis Healing Abutment, which indicates the position it should be placed. If the mark is missing due to the screw access hole placement, the screw hole will guide the insertion.

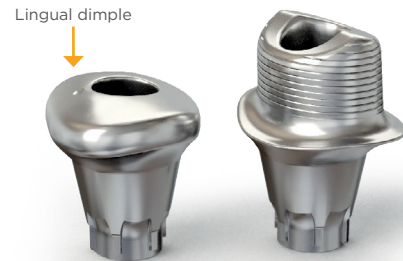

Ideal emergence profile can be provided during the healing phase. (Design based on planned final Atlantis Abutment and crown.)



Easily transferred or adjusted to the final Atlantis abutment. (Dental laboratory can produce the crown using the Atlantis Core File option.)



Minimal interference of the mucosa when installing the final abutment and crown.

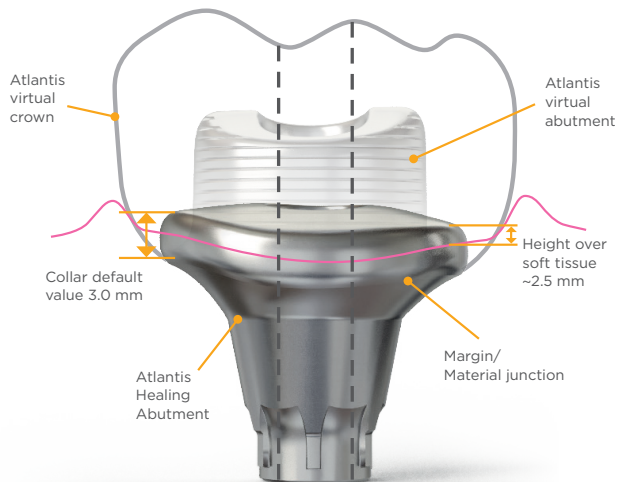

Material and default values

- Titanium or gold-shaded titanium
- Emergence width - Always full anatomical (same as the final restoration)
- Collar height - 3.0 mm
- Height over soft tissue ~2.5 mm

Additional information

For healing abutments, please note that implant manufacturers torque recommendations might differ between healing abutments and final abutments.

Atlantis® Temporary Crown

Together with an Atlantis Abutment the Atlantis Temporary Crown works as a functional, cement- or screw-retained restoration, up to 12 months, until a permanent crown is constructed.

The temporary crown is designed as a full-contour single unit crown, and may be ordered to be in- or out of occlusion. The crowns may be clinically modified by grinding only as necessary to adjust occlusion and contact points.

Material and shades

The Atlantis Temporary crowns are milled from multi-layered (gradient) blocks of PMMA (Polymethyl methacrylate) and can be ordered in 6 different shades.

Note: For more information on multilayer PMMA from Dentsply Sirona, please visit www.dentsplysirona.com.

Cement space and Crown cementation

Atlantis Temporary Crown, is milled with a cement space of 110 µm. Cement should be appropriate for both the abutment and crown material (i.e. temporary cement). Perform cementation in accordance with the IFU from the manufacturer of the cement used.

Screw-retained restorations

The Atlantis Temporary Crown is cemented extraorally to the Atlantis Abutment.

The restoration is placed and tightened and the screw access hole of the crown is sealed.

Note: Available with angulated screw access.

Cement-retained restorations

The Atlantis Abutment is placed and tightened. The screw access hole of the abutment is sealed and the Atlantis Temporary Crown is cemented to the abutment.

Additional information

The design of the temporary crown and abutment may be re-used for the final restoration, by requesting a "Later order" in Atlantis WebOrder. It is always recommended to take a new impression (physical or digital) for the final restoration, however it is also possible to re-use the original impression.

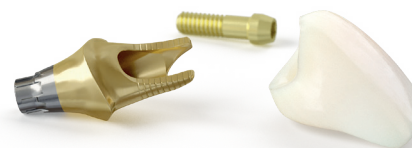

Atlantis® Abutment

For cement-retained crown or bridge restorations, available in titanium, gold-shaded titanium and four shades of zirconia.

Atlantis abutments offer several advantages compared to stock abutments:

- Different choices of emergence widths for a natural and esthetic result
- Margins can be placed at an ideal level for easy and safe removal of excess cement
- Require no chair side modification
- Produced by state-of-the-art milling process to ensure highest precision and quality – every time
- Eliminate the time needed for managing a pre-fabricated abutment inventory



Order preference defaults

When ordering your Atlantis Abutment in Atlantis WebOrder, defaults can be set for most of the design preferences. You can change preferences on an account level as well as within each individual order. If no preferences are set, the defaults listed below will be used when designing the Atlantis Abutment. See Atlantis WebOrder user guide for more details on changing preference default settings.

Order preferences	Availability	Default settings*
Images (for design approval)	Available	N/A
Model (type)	All available	N/A
Atlantis Insertion Guide	Available	No
Material	All available**	N/A
Emergence width options	All available	Contour soft tissue
Margin position options	All available	Use subgingival depth. B/F1.0 mm, D 0.75 mm, M 0.75 mm, L 0.50 mm
Margin design	All available	Chamfer
Retentive surface	Available***	Retentive surface
Atlantis Core File	Available	No
Duplicate abutment	Available	No
Parallelism	Available	N/A
Later order	Available	N/A
Diagnostic wax-up	Available	Recommended for 4 or more edentulous spaces next to each other

* See Atlantis WebOrder user guide for more details on changing preference default settings.

** May vary between implant brands and sizes. Please see Atlantis abutments implant compatibility chart for details.

*** Not available for zirconia.

Atlantis® Crown, Cut-back

The Atlantis Crown, Cut-back is a patient-specific crown with space for porcelain veneering, intended for use with an Atlantis Abutment. Together, these components function as a full single-tooth prosthetic restoration. The cut-back crown is veneered and finalized by the dental laboratory and cemented to the Atlantis Abutment by the clinician as the final stage of the prosthetic procedure.

Cement space

The cut-back crowns are made with a cement space of 40 µm.

Material and shades

The cut-back crowns are milled in seventeen different shades of Cercon xt ML (extra translucent multilayer zirconia) with a Coefficient of Thermal Expansion: $10.1 \times 10^{-6} / ^\circ\text{C}$.

In Atlantis WebOrder it possible to select between maximum, medium or minimum incisal translucency (see next page for more information.)



Cut-back options

The Atlantis Crown, Cut-back can be ordered with 4 different types of cut-back designs enabling case specific flexibility between esthetics and function:

- **Full cut-back** – For full porcelain veneering.
- **Lingual collar** – A lingual collar for easier handling with pliers.
- **Proximal contacts** – Proximal contact points in full contour design, to minimize risks for proximal porcelain cracks.
- **Facial cut-back** – The occlusal, lingual and proximal areas designed full contour with a buccal/facial cut-back design.

Note: The porcelain used for veneering of the cut-back crowns should be applicable for zirconia (see “Material” above) and must be applied and processed in accordance with the IFU from the manufacturer of the porcelain/stain used.



Full cut-back



Lingual collar



Proximal contacts



Facial cut-back

Atlantis® Crown, Full-contour

The Atlantis Crown, Full-contour is a patient-specific crown intended for use with an Atlantis Abutment. Together, these components function as a full single-tooth prosthetic restoration. The full-contour crown may be stained and glazed by the dental laboratory, and cemented to the Atlantis Abutment by the clinician as the final stage of the prosthetic procedure.



Stain and glaze application

Stain and glaze may be applied to the Atlantis Crowns, Full-contour with the following stipulation: Should be formulated to have a CTE (coefficient of thermal expansion) that is appropriate for zirconia (see section “Materials” above).

Note: Application and processing must be carried out in accordance with the instruction for use from the manufacturer of the porcelain/stain used.

Cement space and Crown cementation

Cement should be appropriate for both the abutment and crown material. Perform cementation in accordance with the IFU from the manufacturer of the cement used. The Atlantis Crown, Full-contour is made with a cement space of 40 µm.

Additional information

The Atlantis design technicians will always strive to achieve as good occlusion as possible. However, if e.g. the occlusal contacts are too heavy the Atlantis Crown, Full-contour may be grinded by the dental laboratory and/or clinician. Please note that the Atlantis abutments warranty will still be valid, even if the crown has been grinded.

Material and shades

The full-contour crowns are milled in seventeen different shades of Cercon xt ML (extra translucent multilayer zirconia) with a Coefficient of Thermal Expansion: $10.1 \times 10^{-6} / ^\circ\text{C}$.

In Atlantis WebOrder it possible to select between maximum, medium or minimum incisal translucency.



Atlantis® Crown File

The Atlantis Crown File is a patient-specific “ready-to-mill” digital file of the cut-back or the full-contour crown design, intended for use with an Atlantis Abutment. Together, these components function as a full single-tooth prosthetic restoration.

The Atlantis Crown File is designed by the Atlantis design technicians in the patented Virtual Atlantis Design (VAD) software. The crown file is then uploaded to Atlantis WebOrder for the laboratory to approve before the crown file is downloaded and milled in the laboratory’s in-house milling machine in the preferred crown material.

Two crown file versions: Cut-back or full-contour

The crown files are available as cut-back or as full-contour. With the cut-back version the lab can choose from a set range of cut-back all sides of the crown (see page 13). After milling of the crown the crown



should then be veneered and finalized by the lab before the cementation is done by the clinician. The full-contour crown may be stained and glazed by the lab after the milling and should then be cemented by the clinician in the patient's mouth.

Crown file download

In Atlantis WebOrder you will be able to download the crown file as soon as you have given the design approval:

Order ID	Order reference	Product type	Profile name	Prescriber	Units	Submit date	Materials received	Due date	Status	Case number	ATLANTIS Digital File	Action
43951	test6	Abutment			1	2016-01-25	2016-01-25	2016-01-26	SHIPPED	10927993		Delete
48293	345	Hybrid		n	0				PARTIAL			Delete
48297	345	Bar		v	0				PARTIAL			Delete
43928	Validation Test 34	Bar			1				PARTIAL			Delete

Upload the crown file into the milling software, and proceed with the milling preparations according to the instructions from the particular milling software.

Note: Validation of the design and all design changes must be done within Atlantis Editor before design approval (no changes to the crown design can be done after design approval).

Minimum milling machine requirements

- 5 axis milling machine
- A milling machine that can either handle over-milling or has a capacity to:
 - Mill down to 0.5 mm diameter in “net shape” (no sintering after milling)
 - Mill down to 0.6 mm diameter in “green state” (the crown is sintered after the milling)

- The shrinkage factor depends on crown material and from which manufacturer the material comes from. Refer to the IFU from the crown material (puck) manufacturer
- Puck thickness of the crown material should be minimum 17 mm
- The crown files are delivered in STL-file format, which means that the milling software must be able to process STL-files.

Note: Crown files with angulated screw access is NOT supported for Atlantis CustomBase solution.

Atlantis® Core File

When fabricating the final restoration you can simply download the Atlantis Core File, instead of scanning the Atlantis Abutment yourself. This way you can start the manufacturing of the crown/bridge before the abutment arrives at the lab.

Atlantis Core File is a digital representation of the total case, including the outer surface of an Atlantis Abutment and all scanned data such as soft tissue, adjacent teeth and opposing dentition. Core file eliminates the need to scan the abutment and cast.

Atlantis Core File can be ordered for cement- or screw-retained restorations (with or without screw access hole location). Core file is available both for single and multiple units (including pontics), however not for bridge cases that include prepared teeth.

The core file is easily imported into the preferred design software and enables the digital design of the coping and final restoration before even receiving

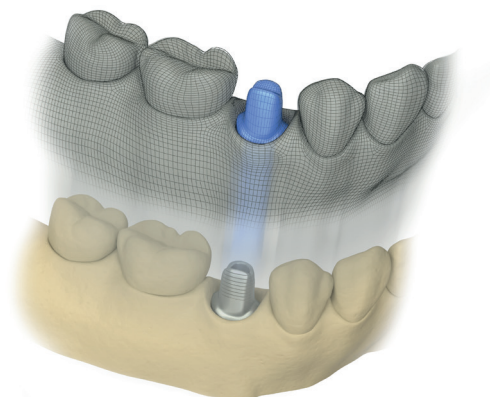

the physical abutment ordered. But, if preferred the core file can also be ordered as a later order after receiving the physical abutment.

Refer to the Atlantis Core File user guide for further information, available in the help page at Atlantis WebOrder.

Atlantis® Insertion Guide

The Atlantis Insertion Guide is a precisely-crafted, 3D-printed device that securely holds an Atlantis Abutment at the correct angle and orientation during installation. The guide can be ordered for single- and multiple-unit cases and is available for the following products:

Atlantis Abutment (for cement-retained restorations)

Atlantis Conus Abutment - overdenture (for attachment retained restorations)

Atlantis Conus Abutment - custom (for attachment retained restorations)

The insertion guide uses adjacent teeth (for single-unit cases) as an index and ensures precise and reliable abutment placement. The Atlantis Abutment scan data, provided by the patented Virtual Atlantis Design (VAD) is used to create the Atlantis Insertion Guide for a perfect design and fit.

For convenience and security, the last digits in the case number are engraved on each guide, and a floss loop allows for a piece of dental floss to be attached, ensuring predictable restorative procedures.



Please refer to the document "Handling procedures for Atlantis Abutment" available in the help section of Atlantis WebOrder, which describes the laboratory and clinical procedure using the Atlantis Abutment together with the guide (for single-unit cases).

Atlantis® Crown Abutment

For single unit screw-retained restorations, an anatomical abutment for direct porcelain application (or composite for titanium) available in titanium and five shades of zirconia including a translucent zirconia in white.

Please consider the following when ordering an Atlantis Crown Abutment. You may also refer to the Atlantis WebOrder user guide for more information.

Diagnostic wax-up

When ordering an Atlantis Crown Abutment, a full-crown, removable diagnostic wax-up is recommended. See page 19 for more information.

Porcelain cut-back

To optimize the porcelain support there is a set range for cut-backs. This range cannot be altered. Cut-back default values can easily be changed within this set range in Atlantis WebOrder.

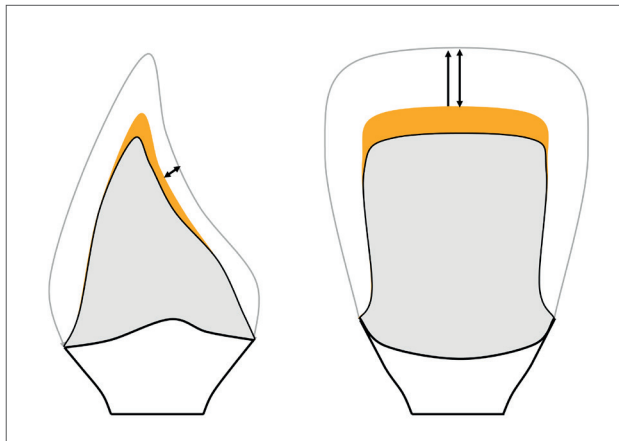

By decreasing the porcelain cut-back on the lingual side, the length of the abutment is increased for effective support of the porcelain/composite.



Region	Range	Default
Buccal/Facial	0.5 - 2.0 mm	1.2 mm
Lingual	0.5 - 2.0 mm	1.0 mm
Distal	0.5 - 2.0 mm	1.0 mm
Mesial	0.5 - 2.0 mm	1.0 mm
Occlusal	0.5 - 2.0 mm	1.2 mm
Incisal	1.0 - 3.0 mm	1.5 mm

Note: Cut-backs may be further altered within the specified range by the Abutment Design Technician in order to achieve a more ideal abutment size. For example:

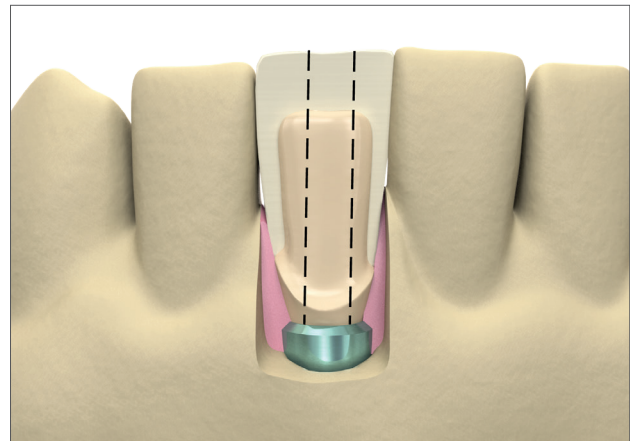

Porcelain/composite cut-backs have to be less on smaller teeth such as lower incisors, upper laterals and in narrow situations to ensure sufficient material for the abutment core.

Angled implant placements

The angle of the implant may limit the possibility to use a screw-retained restoration. It is recommended to check the model with a guide pin or similar before selecting this restoration type.

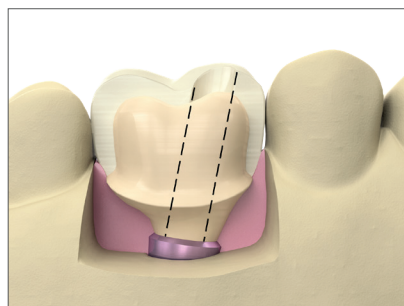

The more angled the placement of the implant, the harder it will be to place a screw-retained crown, as the path of insertion may interfere with the adjacent teeth.

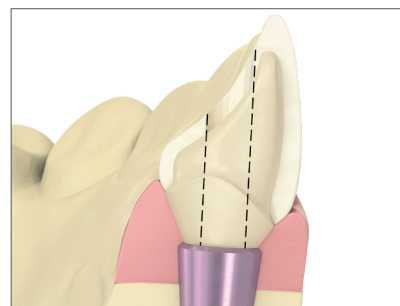
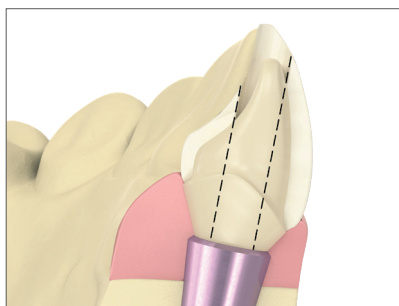

Depending on the position of the implant, the screw access hole may interfere with esthetic and functional outcome of the final crown.

Material

A mask should be used to assure that no porcelain/stain/composite gets on the areas of the interface. Incorrect application of the porcelain/stain/composite could compromise the fit and/or strength of the assembly. Whenever possible, the Atlantis Crown Abutment should be placed in an implant replica during porcelain application to avoid the risk of porcelain particles in the connection area.

Note: It is very important to correctly adjust contact points as the crown is in one piece and has to align perfectly with the implant to prevent failure.

Atlantis® Crown Abutment - zirconia

Yttria-stabilized tetragonal zirconia polycrystals (Y-TZP)

Thermal linear expansion of $10.6 \times 10^{-6}/K^{-1}$

Use appropriate porcelains made for these material constraints.

Application and processing must be carried out in accordance with the instructions for use from the manufacturer of the porcelain/stain used.

Note: The use of zirconia abutments should generally be carefully evaluated before placed in situations with unfavorable loading conditions in combination with small interface diameters.

Atlantis® Crown Abutment - titanium

Ti-alloy (Ti-6Al-4V).

Carefully follow the porcelain and composite manufacture protocol.

Firing porcelain on Atlantis Crown Abutment in titanium creates an oxide layer. If the oxide layer needs to be removed, the implant abutment connection properties must not be changed. Blasting carefully with aluminium oxide 50 µm or glass beads, maximum 2 bar pressure.

Note: Not available for gold-shaded titanium, since porcelain cannot be fused to TiN (titanium nitride). Gold-bonder is not recommended for Titanium Grade 5.

Due to the integrated screw, Atlantis Crown Abutment for Ankylos is not available.

Reminders

- Further changes to porcelain cut-backs may be made by the Abutment Design Technician.
- In the event that a screw-retained solution is not possible due to limitations of the implant case and an Atlantis Crown Abutment was ordered, you will be contacted by a customer support representative.

Atlantis® CustomBase solution

The Atlantis CustomBase solution is a patient-specific dental prosthetic component consisting of an Atlantis Crown, an Atlantis Abutment and Atlantis Abutment screw intended for use with an endosseous implant. Together, the bundled components function as a full single-tooth restoration for screw-retained restorations.

The Atlantis CustomBase solution, is available with:

Atlantis Crown (cut-back or full-contour with angulated screw access option*)

Atlantis Crown File (cut-back or full-contour with screw access) and

Atlantis Core File (with screw access location)

This solution is different compared to a cement-retained restoration. The abutment and crown, part of the unique CustomBase solution, are designed at the same time and should be regarded as one unit, like an Atlantis Crown Abutment.

Margin/material junction: The placement of material junction considering biological principles to ensure healthy soft tissue conditions.

Emergence profile shape (EPS): The solution is designed with customized emergence profile for enhanced soft-tissue management. Patient-specific transmucosal emergence profile from implant level to up to the marginal gingiva, is specifically important for cases with limited space and when esthetics is in focus.

Atlantis Abutment material: The abutment is available in titanium or gold-shaded titanium.

Note: For full interface compatibility please refer to the Atlantis abutments implant compatibility chart.

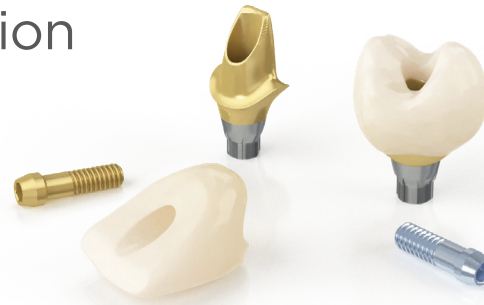
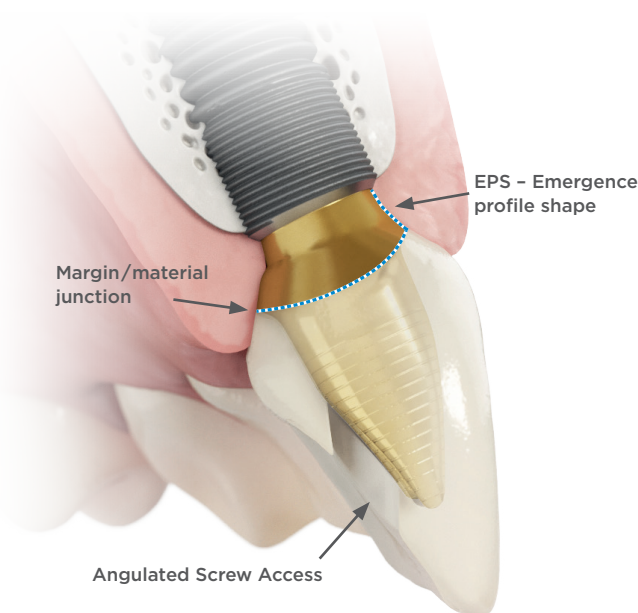

Atlantis Insertion Guide: Not available for screw-retained restorations.

Cementation: The crown with a screw access channel is cemented to the Atlantis Abutment extraorally by the dental laboratory or the clinician, to create a screw-retained restoration. The parts shall be cleaned and sterilized prior to assembly, use gloves. Use a self-adhesive resin cement indicated for bonding zirconia to titanium. Seal the screw channel as it is important to not get cement into the channel.

Note: For angulated screw access option, the Atlantis Screw must be placed into the Atlantis Abutment BEFORE cementation of the Atlantis Crown. Follow cement manufacturer's instructions for cementation. Atlantis abutments have by default a retentive surface, so no need to sandblast the surface, especially not on gold-shaded as the shade is only a thin layer that will disappear if sandblasted.

Angulated screw access*: Allows the screwdriver access channel to be angled up to 30 degrees off the implant axis, for improved esthetics and function. Screwdriver access channel is smaller diameter than the screw head diameter, therefore the screw is captured in the abutment/crown after cementation. Atlantis Angulated Screw Access Screwdriver is required during installation. Order the screwdriver and your choice of driver handle in Dentsply Sirona Implants eCommerce.

Note: Angulation on implant that use torque 30 Ncm or more, will be limited up to 20 degrees due to preventing too high forces on screwdriver tip and the ASA feature. Not available for Crown file option.



*Refer to Atlantis abutments compatibility chart for availability assortment.

Atlantis® CustomBase solution with Atlantis® Crown

This bundled solution consists of an Atlantis Abutment, an Atlantis screw and an Atlantis Crown with screw access hole.

laboratory to stain/glaze). The crown should be cemented to the Atlantis Abutment extraorally and function as a screw-retained, single-tooth restoration.

The crown can be ordered as a cut-back crown (for the laboratory to veneer) or as a full-contour (for the

Note: Also refer to page 14, 16 and 17 for more information regarding the Atlantis Crowns.

View, edit and approve the design using the Atlantis Editor.

Dentsply Sirona fabricate and deliver the crown, abutment and screw.

Laboratory finalizing the crown, glaze if a full contour, or layer porcelain if a cut-back crown.

Extraoral cementation - Seal the screw hole and follow manufacturer's instruction for cementation.

Final restoration ready to be installed by the clinician

Extraoral cement procedure for angulated screw access

Try-in before cementation is recommended.

1. Clean all parts. Insert the screw into the abutment BEFORE cementation of the crown. The screw cannot go through the screw access hole after cementation.
2. The screw head and screw chamber must be protected from cement using suitable materials that are easy to remove before the cement has fully cured.
3. Apply cement onto the abutment and fully assemble the crown and abutment.
4. Carefully remove and clean excess cement from the material junction, the screw access hole and inside the screw chamber. The screw is now captured inside the solution and use the screwdriver to confirm the screw is free to move inside.
5. Clean and polish before install the restoration using the Atlantis Angulated Screw Access Screwdriver.

Atlantis® CustomBase with Atlantis® Crown File

This bundled solution consists of an Atlantis Abutment and an Atlantis Crown File with screw access hole. The crown can be ordered as a cut-back crown (for the laboratory to veneer) or as a full-contour (for the laboratory to stain/glaze). The crown file is imported into the laboratory's milling software and milled in the in-house milling machine. When the crown has

been finalized, it should be cemented to the Atlantis Abutment extraorally and function as a screw-retained restoration.

Note: Not available for angulated screw access option. Also refer to page 18 for more information on the Atlantis Crown Files.

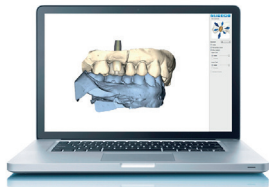

View, edit and approve the design using the Atlantis Editor. The crown file is not editable after exported.



Dentsply Sirona fabricate the abutment.



The customer downloads the crown file in Atlantis WebOrder, and uploads to preferred milling software. Milling and finalizing the crown at the laboratory.

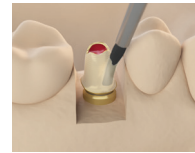

Extraoral cementation - Seal the screw hole and follow manufacturer's instruction for cementation.



Final restoration ready to be installed by the clinician.

Atlantis® CustomBase solution with Atlantis® Core File

This bundled solution consists of an Atlantis Abutment, an Atlantis screw and an Atlantis Core File with screw access location. Atlantis Core File is a digital file of the total case, including the outer surface of the Atlantis Abutment.

the screw access channel. The screw access channel file is used as a guide during the restoration design to add the screw access channel hole.

Note: The crown created from the Atlantis Core File should be cemented to the Atlantis Abutment extraorally and function as a screw-retained restoration.

The dental laboratory import the core file to their preferred software. The core file includes an additional STL file(s) that displays the location and diameter of

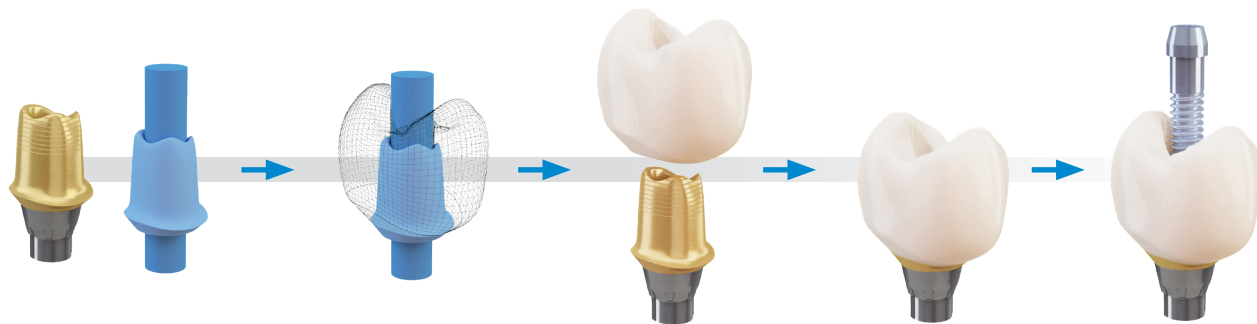

Atlantis Abutment and Atlantis Core File with screw access location. Import the core file to preferred software.

The dental laboratory design the final coping/crown digitally for milling.

The crown should be cemented to the Atlantis Abutment extraorally and function as a screw-retained restoration.

Crown cemented by the dental laboratory or the clinician.

Final restoration ready to be installed by the clinician.

Atlantis® Conus Abutment - overdenture

Atlantis Conus Abutment - overdenture, are parallel, one-size abutments for removable prostheses. Intended for a removable, attachment-retained non-resilient overdenture as a complement to resilient solutions such as Ball or Locator abutments.

The position of the abutments will be in relation to the space needed for the final restoration and a diagnostic tooth set-up is always required. Abutments will be placed with margin levels as close to soft tissue level as possible.

The abutments will be delivered together with an mandatory Atlantis Insertion Guide, for easier insertion. Refer to Atlantis Conus Concept manual.



Atlantis® Conus concept

The combination of the Atlantis Conus Abutment - overdenture together with the friction-retained SynCone cap, is known as the Atlantis Conus Concept.

Atlantis Conus Abutment - overdenture is designed to fit SynCone 5° cap. The prefabricated SynCone caps are ordered in Atlantis WebOrder. The SynCone cap is available both with and without retention, material Degulor® 3406 (see table below).



Available products to order in Atlantis WebOrder:	Component	Reference number (USX), if/when order from Dentsply Sirona e-commerce
SynCone cap - Retention		3102 2198
SynCone cap - Without retention		3102 2199
Polymerization sleeve for SynCone		3102 1405

For more information, refer to the “Atlantis Conus Concept” manual.

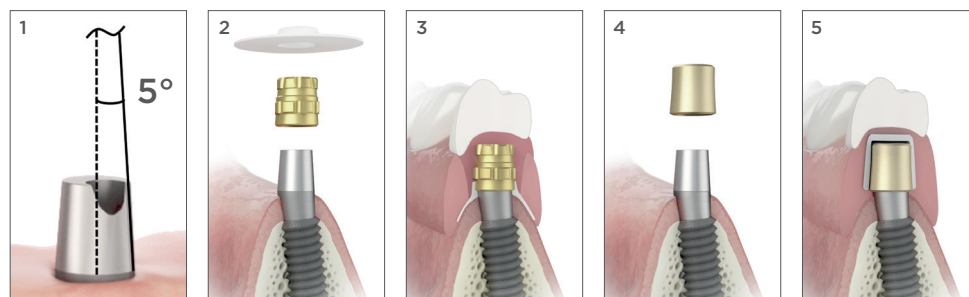

1. Cone dimensions made to fit SynCone 5° caps.
- 2-3. SynCone cap with retention and sleeve for polymerization.
- 4-5. SynCone cap without retention for metal framework.

Considerations for restorative planning

When planning the prostheses, please note the variation that can occur when a SynCone cap is seated on an Atlantis Conus Abutment - overdenture, due to machining tolerances. The height can have a variation of +/- 0.4 mm (red-marked lines in the 3D Editor image below).

Note: For Atlantis Conus Abutments, a minimum of four implants are recommended. Atlantis Conus Abutments can not be used in combination with other abutment types for the same case (e.g. Atlantis Conus Abutment and Atlantis Crown Abutment in the same restoration).

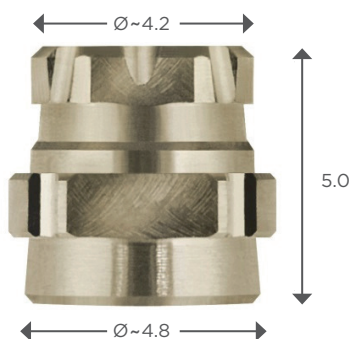
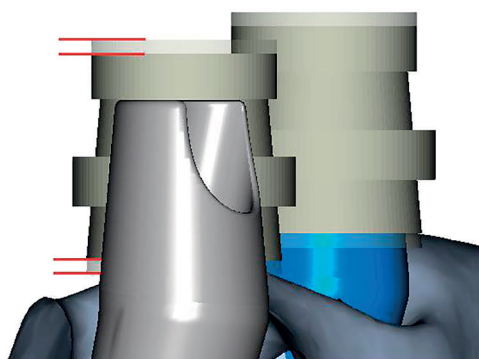

Order preferences	Availability	Default settings*
Images (for design approval)	Required	Required
Model (type)	Stone model with removable silicon soft tissue	Stone model with removable silicon soft tissue
Atlantis Insertion Guide	Yes	N/A
Material	Titanium	Titanium
Emergence width options	No	N/A
Margin position options	No	Will be made as close to soft tissue level as possible
Margin design	No	N/A
Taper	5.0°	5.0°
Retentive surface	No	No
Atlantis Core File	No	No
Duplicate abutment	Yes	No
Parallelism	All abutments included will be parallel	All abutments included will be parallel
Later order	Yes	N/A
Diagnostic wax-up	Required	Required

Atlantis® Conus Abutment - custom

Atlantis Conus Abutment - custom, are parallel individualized abutments mainly for removable bridge constructions.

Intended for a removable non-resilient, attachment-retained bridge or overdenture. These are more individualized type of abutments than the overdenture abutments and will therefore not have a pre-set shape (will not fit with SynCone caps). The default taper angle for the Atlantis Conus Abutments - custom is set to 1°.

The position of the abutments will be in relation to the space needed for the final restoration and a diagnostic tooth set-up is always required. As default the margins will be placed as close to the soft tissue level as possible. This contributes to easy insertion and removal of the bridge by the patient.

A removable bridge construction demands sufficient material thickness of the abutments around the screw



access hole in order to achieve proper retention and durability. The Atlantis Conus Abutment - custom, will therefore be designed with narrow shoulder widths and occasionally, with increased soft tissue compression.

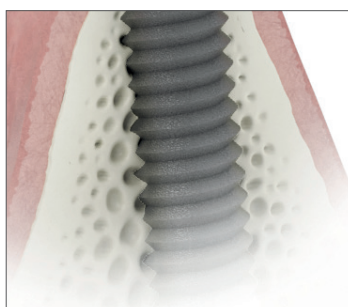
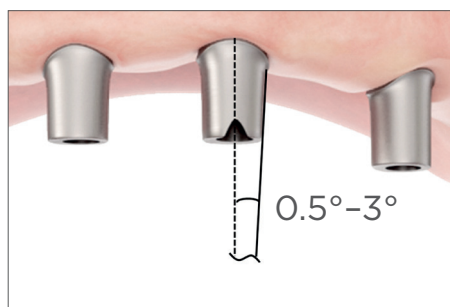

Note: Atlantis Conus Abutment - custom is not compatible for mixed cases (e.g. Atlantis Conus Abutment and Atlantis Crown Abutment in the same restoration).

Order preferences	Availability	Default settings*
Images (for design approval)	Required	Required
Model (type)	All available	N/A
Atlantis Insertion Guide	Available	No
Material	Titanium and gold-shaded titanium	N/A
Emergence width options	All available	Contour tissue
Margin position options	All available	Use subgingival depths
Margin design	All available	Chamfer
Taper	0.5°, 1.0°, 1.5°, 2.0°, 2.5° and 3.0°	1.0°
Retentive surface	No	No
Atlantis Core File	Yes	No
Duplicate abutment	Yes	No
Parallelism	All abutments included will be parallel	All abutments included will be parallel
Later order	Yes	N/A
Diagnostic wax-up	Required	Required

*Refer to the Atlantis WebOrder user guide for more details on changing preference default settings

Duplicate abutment

A functionally identical duplicate of the original abutment that is ordered and delivered together with the original abutment. The two abutments provided will be identical in material and design.

One of the abutments can be used by the clinician for placement of a temporary restoration while the other is used by the laboratory to produce the final restoration.

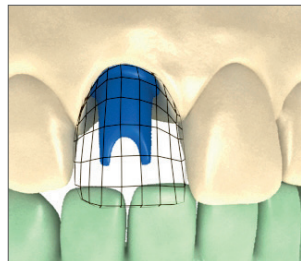
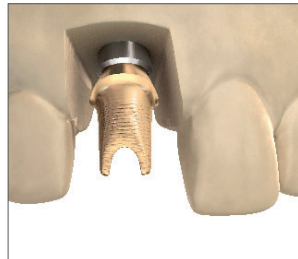

Image from Virtual Atlantis Design (VAD).



Clinical

The original abutment for the clinician placed to support a temporary crown.



Laboratory

A duplicate of the original abutment is used by the laboratory to fabricate the final restoration.



Final restoration in place.

Later order

Orders of original Atlantis abutments can be placed at a later time with or without changes to the existing abutment design. If changes in the patient's tissue dimensions occur, later order abutments allow for modifications to be made to an existing abutment design (see two examples below).

For cases with no visible soft tissue or dentition changes it is recommended to use the scans from the initial order¹, but for cases with larger changes to the soft tissue or dentition, either a new arch scan or a full re-scan is recommended.

Atlantis Tissue Sculpting Concept was utilized during the soft tissue healing

Place a later order in Atlantis WebOrder re-using the original design that was created during the healing phase.

Note: See pages 13-15 for more information.



Ideal emergence profile can be provided during the healing phase. (Design based on planned final Atlantis Abutment and crown.)



Easily transferred or adjusted to the final Atlantis abutment. (Dental laboratory can produce the crown using the Atlantis Core File option.)



Minimal interference of the mucosa when installing the final abutment and crown.

The soft tissue has receded and the abutment margin is showing

Place a later order in Atlantis WebOrder using the original design and lower the abutment margin.

Note: Not guaranteed to be a functionally identical duplicate.

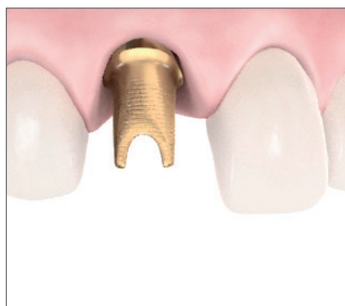

The soft tissue has receded.

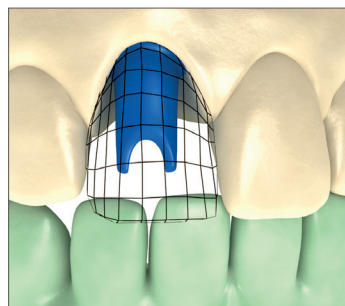

Image from Virtual Atlantis Design (VAD) with original abutment design modified.



New abutment for final restoration.

¹A full re-scan is mandatory for orders older than 5 years (later order price still applies).

Atlantis® Printed Model

The Atlantis Printed Model is intended for use as a working model when ordering Atlantis abutments with intraoral scanning (available for all different Atlantis abutment restoration types).

The models are 3D printed in a light cure plastic material and are delivered with:

- Removable and translucent soft tissue
- Installed Elos Accurate Analog for Printed Models
- 3-pin positioning of bite orientation
- Pre-made pockets for vertex articulators

To ensure accuracy all models are re-scanned after printing to compare the printed models with the incoming scan data received from the intraoral scanner.

Note: Atlantis Printed Model is only intended to be used to restore the ordered Atlantis abutment(s). Dentsply Sirona cannot take responsibility for any off label use other than this.

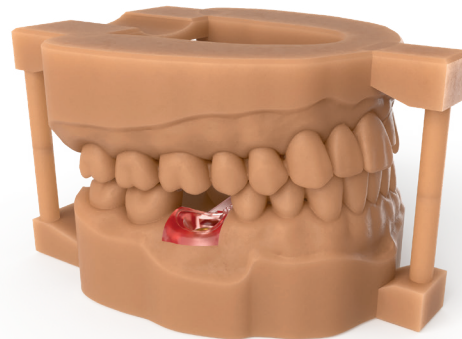

Diagnostic wax-up

When there are four (4) or more adjacent edentulous spaces, a diagnostic wax-up/scan file is recommended. A removable diagnostic wax-up for three (3) or less adjacent edentulous spaces can be

provided to supply additional information such as buccal-lingual dimensions, occlusal height and offset width.



The diagnostic wax-up can be made with or without the silicone soft tissue mask in place. The wax-up (acrylic) must be accurately secured to the master cast.



On the model, a temporary cylinder or similar can be used as a support on one or two of the analogs to fabricate a wax or acrylic diagnostic “wax-up”.



All cases must be articulated before being shipped to Dentsply Sirona. Make sure to verify that the models are in correct occlusion.

Stone models

The type of soft tissue model provided will dictate the abutment design options available to you.

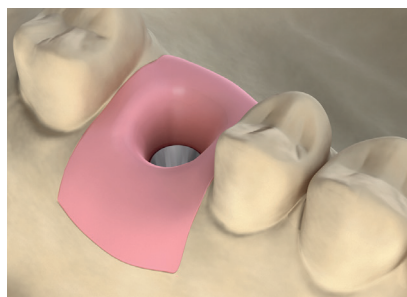

Stone model with removable soft tissue

Abutment design options available:

- All margin positions
- All emergence width options

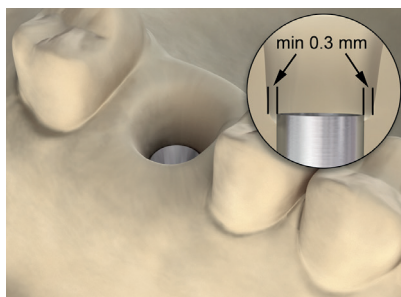

Stone model of soft tissue

Abutment design options available:

- All margin positions
- No Tissue Displacement (emergence width option 4) only

Note: Analog must have 0.3 mm radial clearance to allow processing.

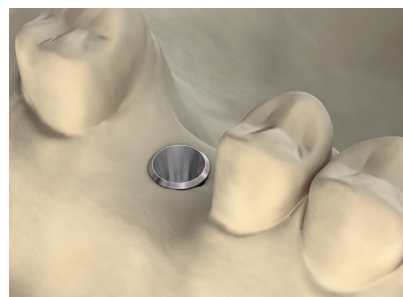

Stone model - no model of soft tissue

Abutment design options available:

- Margin positions measured from implant surface to abutment margin (Margin position B) or make abutment margin as close to interface as possible (Margin position C)
- All emergence width options

Articulator guide

The accuracy of the Atlantis process is dependent on the quality of properly articulated cases. A proper bite registration will ensure the best possible final result for the patient.

All cases must be articulated before being shipped to Dentsply Sirona. Verify that the models are in correct occlusion. For single unit and less complicated cases, an ocludator can be used. The articulator must

fit in the Atlantis CaseSafe. For detailed shipping information please refer to "Atlantis shipping guide" available in the help section of Atlantis WebOrder.

Note: If this is not possible to fit the articulator in the Atlantis CaseSafe provided, use your own packaging and make sure it is packed and shipped properly to avoid breakage during shipping.

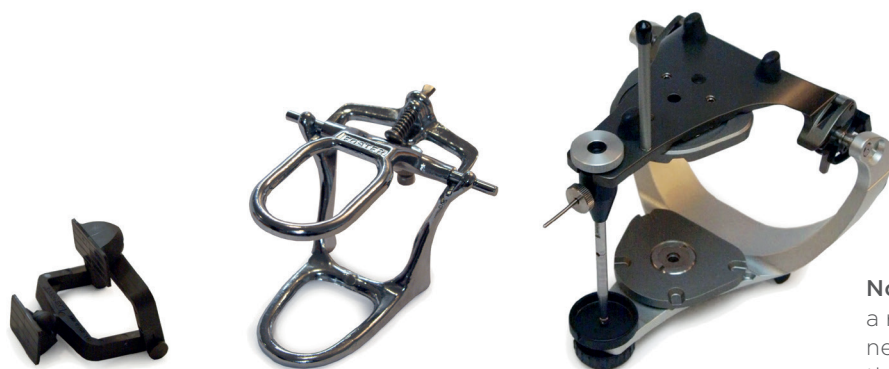

Note: If using an articulator with a removable base plate, it is only necessary to ship the cast mounted on the plate and not the entire articulator.

Design terminology

Basic landmarks – anterior design

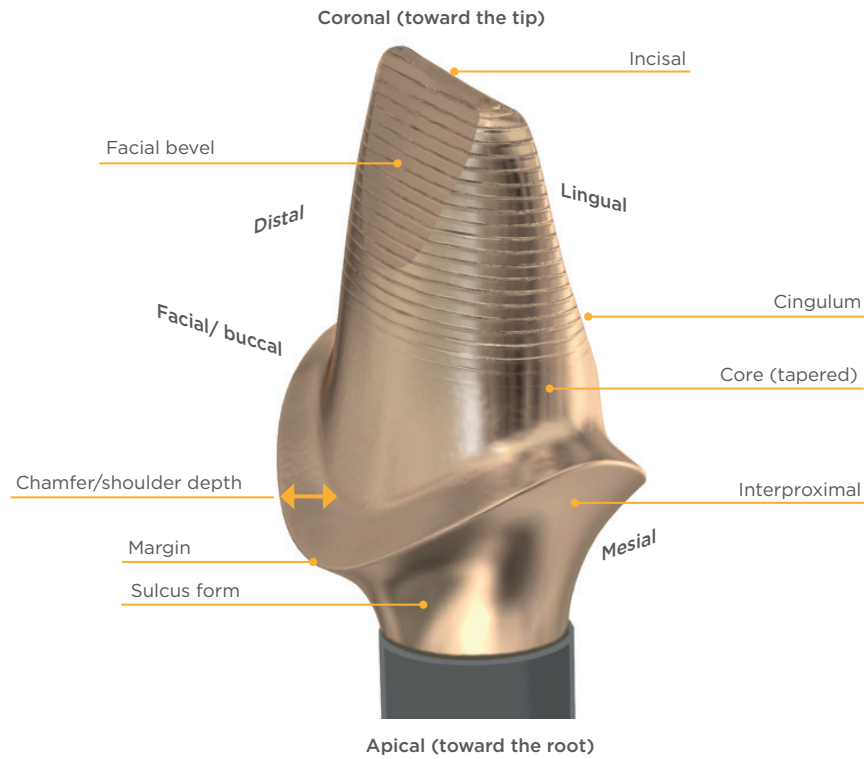

Basic landmarks – posterior design

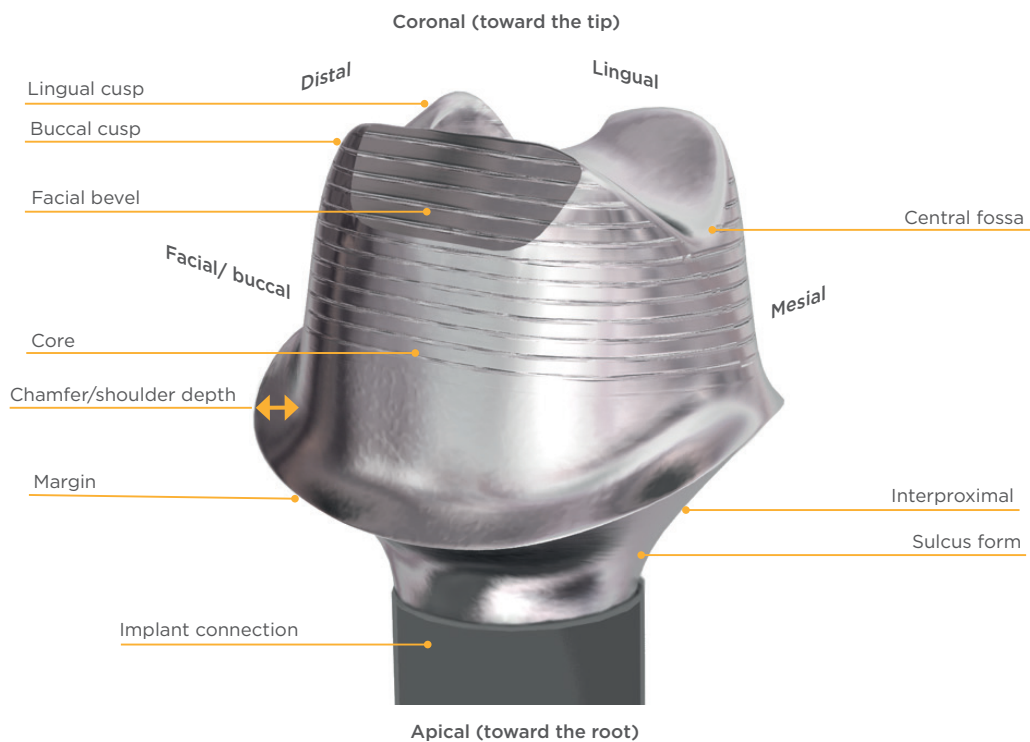

Questions and answers

Atlantis® CustomBase solution with angulated screw access (ASA)

Q: *What is the maximum degrees angulation for this solution?*

A: Depends on the interface and can vary from case to case, max up to 30°. Angulation on implant that use torque 30 Ncm or more, will be limited up to 20 degrees due to preventing too high forces on screwdriver tip and the ASA feature.

Q: *What torque should be used for restorations with angulated screw access?*

A: Refer to recommended torque in the Atlantis abutments screw torque recommendation chart, available in Atlantis WebOrder helpsection.

Q: *Are Astra Tech Implant EV ASA screws color coded?*

A: No, as it will be a potential risk to mix up the regular Astra Tech Implant EV screw with Astra Tech Implant EV ASA screw if same color-coding. ASA screws are not anodized.

Q: *Are the design of Atlantis ASA screws identical with the Suprastructure ASA screw?*

A: Yes, for Astra Tech Implant EV interfaces, but won't be the same for every implant interface.

Q: *How should the Atlantis Angulated Screw Access Screwdriver be cleaned and sterilized?*

A: Normal routines for reusable instruments, refer to e.g:32671183_ATIS EV screw-retained restorations manual, page 47-48. IFU 4195_Drills EV.

Q: *If failure, how to remove the cement without damage the products?*

A: Best practice from our customers: Place the restoration on suitable dental ceramic firing material. Porcelain furnace stand-by temperature - max 400° for ~5-10 min. Carefully clean all parts, use glass beads.

Q: *For multiple unit cases, why can't I order ASA for all abutments? Even if the ASA feature is not needed, it would be beneficial to get the same ASA screw for all abutments in the case (clinician can then use same ASA screwdriver during installation).*

A: Not all cases are suitable for ASA and we don't cover all brands and sizes. The ASA screw head is larger than the regular Atlantis abutment screw and can be a limitation for the design, e.g. not sufficient strength due to lack of space.

Q: *How can the clinician identify what screw driver to use (ASA or regular driver)?*

A: The product label on the box that the abutment is delivered in is marked "Screw Access: ANGLED or STRAIGHT".

Atlantis® Conus Abutment – For attachment-retained restorations

Q: *What are the unique benefits of Atlantis Conus Abutments in comparison to alternative options for attachment-retained restorations?*

A: Atlantis Conus Abutments are available for all major implant systems and are produced using the advanced Virtual Atlantis Design (VAD) software which ensures parallelism for optimal attaching and removal of the prosthesis. In addition, no stock abutments are needed, eliminating the cost and time needed for inventory management.

Q: *What is the difference between a "resilient" vs. "non-resilient" attachment?*

A: An attachment-retained, tissue-supported prosthesis has mobility within the retaining mechanism of the attachment, making it resilient.

Example: Locator or other attachments with housing and a nylon or plastic insert.

A non-resilient attachment is implant-supported and has a fixed position when activated or fully engaged.

Example: Atlantis Conus Abutment – overdenture.

Q: *Will the parallelism of the abutments be affected when using the Atlantis 3D Editor?*

A: No. The Atlantis Conus Abutment will remain parallel.

Q: *What is a taper angle?*

A: A taper angle is the convergence angle of the vertical abutment core walls. This will determine the friction fit of the restoration; the smaller the angle, the higher the friction.

Q: *What is the range of taper angle for an Atlantis Conus Abutment – custom and what is the default?*

A: The taper angle for Atlantis Conus Abutment – custom (always stated as half the taper angle) is available in increments of a range of 0.5° to 3°, with the default being 1°.

Q: *Why are Atlantis Conus Abutments not available in zirconia?*

A: The friction characteristics of zirconia on the caps are not consistent over time, as the zirconia tends to wear on the cap material.

Q: *Why is Atlantis Conus Abutment – overdenture not available in gold-shaded titanium?*

A: The cervical part of the Atlantis Conus Abutment – overdenture where the gold-shaded titanium layer would be, will be covered and not visible, once the prosthesis is placed.

Atlantis® Core File

Q: *What are the advantages of using Atlantis Core File?*

A: Incorporating Atlantis Core File into your workflow allows you to utilize your time to design the restoration, instead of scanning the model and Atlantis Abutment. In addition, you can eliminate time spent on scanning and re-scanning, and cleaning the model and components after the scanning process.

Q: *Can I order the Atlantis Core File for abutments in all materials?*

A: Yes. Atlantis Core File is a digital representation of the Atlantis Abutment regardless material choice.

Q: *How close is the Atlantis Core File to the actual abutment part?*

A: The Atlantis Core file is an accurate representation of the outer surface of the abutment.

Q: *Is the Atlantis Core File a scan of the Atlantis Abutment?*

A: No. The core file is a digital file that is created by simulating the machining process of an Atlantis Abutment.

Q: *Will I receive a notification if the Atlantis Core File cannot be created?*

A: Yes. If there is a problem during the creation of the core file, you will be notified via e-mail. A note will be posted in your Atlantis WebOrder account as well.

Q: *Can I change the abutment design after I receive the Atlantis Core File?*

A: No. Changes cannot be made after the Atlantis WebOrder is in the "shipped" status.

Q: *How long is the Atlantis Core File available for download in Atlantis WebOrder?*

A: The core file is available in Atlantis WebOrder for 30 days.

Q: *Can I call Dentsply Sirona Customer Service after 30 days to request the Atlantis Core File ordered previously?*

A: No. After 30 days following the time of order, the core file will not be available.

Q: *Can I order an Atlantis Core File in a Later Order?*

A: Yes. The core file may be ordered with a Later Order of an Atlantis Abutment but not without an abutment.

Q: *Is Atlantis Core File available for scanned cases only?*

A: It can be ordered for all scanned cases and also for orders shipped in with Atlantis CaseSafe.

Q: *What softwares can Atlantis Core File be used in?*

A: Atlantis Core File is available for all systems.
Note: Crowns for screw-retained restorations (Atlantis CustomBase solution) cannot be milled with CEREC SW, i.e. core file is NOT supported for screw-retained solutions when using CEREC SW.

Q: *Is the same file format used for all design softwares?*

A: Core file is an STL file that is included in a specific file format packaged in a compressed format. Atlantis Core File is available in specific formats for inLab, CEREC, 3Shape, Dental Wings, DWOS Lava Edition and Exocad. Thus to have the best possible workflow in the used software. For all other open design softwares a generic format is available, .zip. Download the correct format for the software that will be used when designing the restoration:
 CEREC SW and inLab CAD SW: "ACF.dxd"
 3Shape: "ACF.3oxz"
 Dental Wings/Lava: "ACF.xorder"
 exocad: "ACF.exo"
 Generic format: "ACF.zip"

Q: *Will I need to learn a different design workflow when using the Atlantis Core File (e.g. new design parameters)?*

A: No. You can continue using the design workflow you normally use.

Q: *What kind of milling system can I use to machine crowns using Atlantis Core File?*

A: You can use any milling center that accepts open format (STL).

Note: The crown milling machine might have limitations in milling the inner geometry of a crown that fits a patient specific abutment design. The reasons for that can be many such as:

- To big radiuses of the milling tool
- No possibility to over mill narrow inner geometries
- A crown material that limits the thickness of the crown

Q: *Who should I call if I have a problem or question when ordering or importing an Atlantis Core File?*

A: Please contact the local Dentsply Sirona Customer Service.

Atlantis® Insertion Guide

Q: How do I order the Atlantis Insertion Guide?

A: In Atlantis WebOrder, under the section where you indicate the implant locations on the "Overview tab." Please note, if you are selecting an implant or product on the "Items tab" that is not compatible with a guide, you will receive a warning notification.

Q: Are the guides sterile or non-sterile when sent from Dentsply Sirona?

A: The guides are non-sterile when sent from Dentsply Sirona (see Atlantis abutments IFU for recommended disinfection procedure).

Q: Is it possible to order a guide also for lab-based scanned orders?

A: Yes. But please keep in mind that in order to create the guide, as much neighboring dentition possible is needed. As a result, please do not trim away neighboring dentition when you want to order an Atlantis Insertion Guide.

Q: Why is it even more important to send sharp and accurate models (scans or physical) to Dentsply Sirona when ordering guides?

A: If the master model does not fully replicate the dentition in the patient's mouth, the guide might fit the model but not in the patient's mouth. The following can be reasons for this:

- Chipped master model
- Voids in master model pour
- Distorted impression

Atlantis® Crown Abutment, titanium

Q: Can the Atlantis Crown Abutment be ordered in gold-shaded titanium?

A: No. Porcelain cannot be fused to titanium nitride coating.

Q: Which type of porcelain can be used for Atlantis Crown Abutments in titanium?

A: Only porcelains formulated for use with titanium such as Vita Titan, Duceram Kiss/DeguDent, Triceram and Titzian, should be used.

Q: Can I use gold-bonder?

A: Based on the less than optimal results, including bubbles/cracks in the porcelain that occurred during beta testing, the use of gold-bonder is not recommended.

Q: Do I need to clean the surface of the abutment before the porcelain is applied?

A: Please refer to the standard surface cleaning instructions of the porcelain manufacturer. If blasting is used, be sure to protect the implant connection area of the abutment, preferably with an implant replica.

Q: What temperature should be used when firing porcelain on titanium?

A: The firing conditions should always be in accordance with the porcelain manufacturer's instructions.

Q: How do I remove the oxide layer?

A: Caution is required when removing the oxide layer to avoid damage to the implant connection area. Blast with low pressure and be careful in the implant seat/conical part of the abutment. During the beta tests, laboratories used aluminum oxide 50 µm, 1 bar. Finish with glass beads 50 µm, max 2 bars.

Q: Why is it so important to protect the implant connection surface when polishing the abutment between the implant interface and the porcelain?

A: The implant interface can be damaged during polishing if it is not protected by an implant replica or similar. The interface connection will be compromised and as a result, the abutment may fracture.

Q: *What is the default cut-back for Atlantis Crown Abutment in titanium?*

A: Same as for Atlantis Crown abutments in zirconia. In Atlantis WebOrder, the values can be easily changed within a range for each area, or by using the Atlantis 3D Editor.

Q: *Is it possible to order approximal contact points in titanium or zirconia?*

A: It is possible to order a 0.5 mm cutback in Atlantis WebOrder. If less is requested (contact points), this has to be specified under "Additional Case Instructions." When approximal contacts have been requested, the designer will try to create contacts, as much as possible, but there are limitations and not every case will be producible: e.g. too large and/or too angled for production. The exact shape of the neighboring teeth will not be possible to replicate if contact points are requested.

Q: *Is it possible to use composite on Atlantis Crown Abutment in titanium?*

A: Yes, it is recommended to follow manufacturer's protocol, and if needed, adjust "porcelain" cut-back in Atlantis 3D Editor before approve the design to production.

Q: *Can I order Atlantis Crown Abutment for Ankylos?*

A: Atlantis Crown Abutment for Ankylos is not available due to the integrated screw that will be affected then fusing porcelain.

THE DENTAL
SOLUTIONS
COMPANY™

